



RED-DOT-RACK TRIPOD KIT INSTALLATION MANUAL



1.0 OVERVIEW	3
2.0 PRODUCT RANGE.....	4
2.1 Range of Rooftop Components.....	4
3.0 PREPARATION FOR INSTALLATION	5
3.1 Applications.....	5
3.2 Tools for Installation	5
4.0 PLANNING THE INSTALLATION	6
4.1 Site Locations	6
4.2 Building / Installation Height.....	7
4.3 Solar Panel Layout.....	7
4.4 General Installation Notes	8
4.5 Fastening Torque of Bolts	8
5.0 INSTALLATION OF MOUNTING BRACKETS.....	9
5.1 Installing Directly onto Corrugated Rooftops	9
5.2 Installing onto Corrugated Rooftops with Corrugated Shoe (optional).....	10
5.3 Compression Coupling Bracket Mounting Instruction	11
5.4 Tripod Tilt Leg Setup	12
5.5 Rail Fastening Instruction.....	13
5.6 Rail Splice Instruction.....	15
5.7 Solar Panel Module Installation	16
5.8 End Clamps.....	17
5.9 Mid Clamps.....	18
5.0 GROUNDING COMPONENTS	19
5.1. Mid Clamp Earthing Washer	19
5.2. Earthing Lug.....	20
6.0 Bracket Spacing Guidelines	21
6.1. Bracket Spacing for Tripod (Solar panel 60cell)	21
6.2. Bracket Spacing for Tripod (Solar panel 72cell)	23
7.0 CONTACT DETAILS	25

1.0 OVERVIEW

Thank you for choosing RED-DOT-RACK for supplying your solar mounting systems. RED-DOT-RACK mounting systems have been designed using the highest quality materials and engineering expertise in their design and manufacture.

All of RED-DOT-RACK rooftop mounting systems can be used in a wide range of installation locations such as; rural, industrial, commercial or residential. The mounting systems can be installed in coastal areas with corrosive environmental conditions and regions with cyclonic winds when installing the system in compliance with the guidelines in this manual.

All products come backed with a 12 year warranty as subject to the terms and conditions in the RED-DOT-RACK product warranty document.

Safety Instructions

- Installation of the mounting systems should be performed by a trained professional only. Poor installation methods can result in damage to the solar plant and the existing building structure and may present a risk to others.
- There is a risk of falling when working at heights such as a building rooftop. Safety regulations must be implemented and followed including the provision of safety equipment for all workers, securing the installation site and installing signage to warn people of the risks in the area.

The installer is solely responsible for:

- Complying with all applicable local and national building codes;
- Ensuring that all products used in the installation are appropriate for the particular installation type and location;
- Ensuring that the existing building and roof structure provides the load bearing capacity for installing the entire solar PV system including mounting systems, modules and electrical equipment under live building load conditions;
- Ensuring only RED-DOT-RACK parts are used in the installation of the mounting hardware. Substitution of third party products may lead to a failure in the RED-DOT-RACK system and void any warranty claims;
- Maintaining the watertight integrity of the roof;
- Ensuring safe installation of all components of the system
- Verifying that other loading factors including water, ice, snow and seismic loads do not affect the installation.

2.0 PRODUCT RANGE

RED-DOT-RACK offers a wide range of rooftop solar mounting systems to allow for the installation of solar on almost any type of roof surface in the world. Rooftop mounting systems cover applications for both flat and raised installation on pitched metal roof and for flat concrete slabs. RED-DOT-RACK provides all the components you need to successfully install your system in any part of the world.

2.1 Range of Rooftop Components

 <p>XL Folded Tripod Tilt 0-30 deg</p>	 <p>Folded Tripod Tilt 0-15 deg.</p>	 <p>Folded Tripod Tilt 15-30 deg.</p>
 <p>Earthing Washer</p>	 <p>Earthing Lug</p>	 <p>T-Bolt Connector</p>
 <p>Adjustable Mid Clamp</p>	 <p>Adjustable End Clamp</p>	 <p>Rail Splice</p>
 <p>KlipLok 700 Bracket</p>	 <p>KlipLok 406 Bracket</p>	 <p>KlipLok EPDM Rubbers</p>
 <p>Corrugated Roofing Shoe</p>	 <p>Cross Rail Bracket</p>	 <p>Rail: 2100mm, 4200mm, 5200mm</p>

3.0 PREPARATION FOR INSTALLATION

3.1 Applications

The RED-DOT-RACK TRIPOD mounting system is designed for installation on commercial buildings in urban and rural locations. This system allows for modules to be installed on flat concrete rooftops or metal sheet rooftops with pitch of up to 7 degrees.

3.2 Tools for Installation

You will need the following tools for installing the Red-Dot-Rack Tripod mounting system.

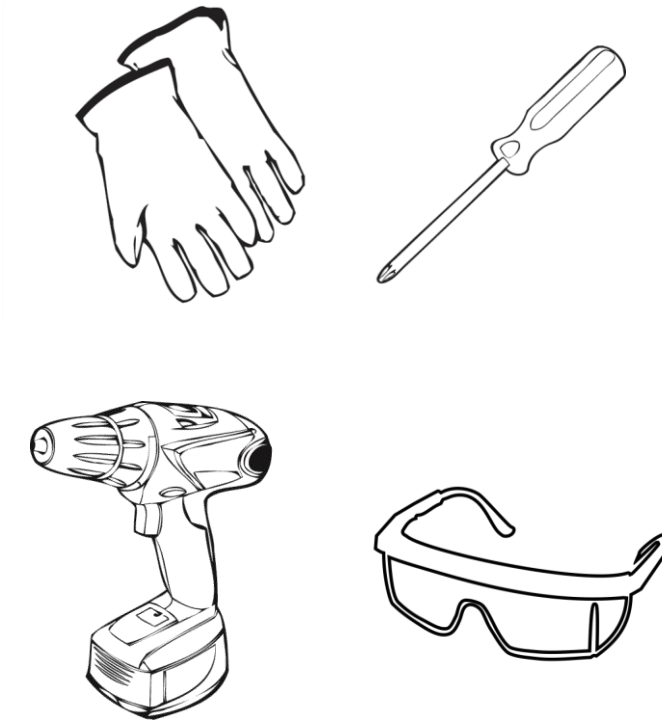

1. Cordless drill
2. Protective gloves and clothing
3. Protective eyewear
4. Screw drivers, including Phillips head driver and Torx head

4.0 PLANNING THE INSTALLATION

Red-Dot-Rack rooftop mounting systems have been developed in accordance with Australian standards AS1170.2 to suit a wide range of roof types and environmental conditions around the world. Guidelines for installing fixtures for different systems are provided in this installation manual.

Should your system requirements fall outside of the guidelines provided, please contact a Red-Dot-Rack technician before proceeding with the installation.

4.1 Site Locations

Locations in Australia are subject to different wind structural loadings in accordance with the requirements identified in AS 1170. The Red-Dot-Rack Tripod mounting system has been designed to be installed in all location in Australia where installations are located in Regions A, B, C or D. This includes all major city and suburban regions of Sydney, Melbourne, Brisbane, Adelaide, Canberra, Hobart and Perth. See figure 1 for wind areas.

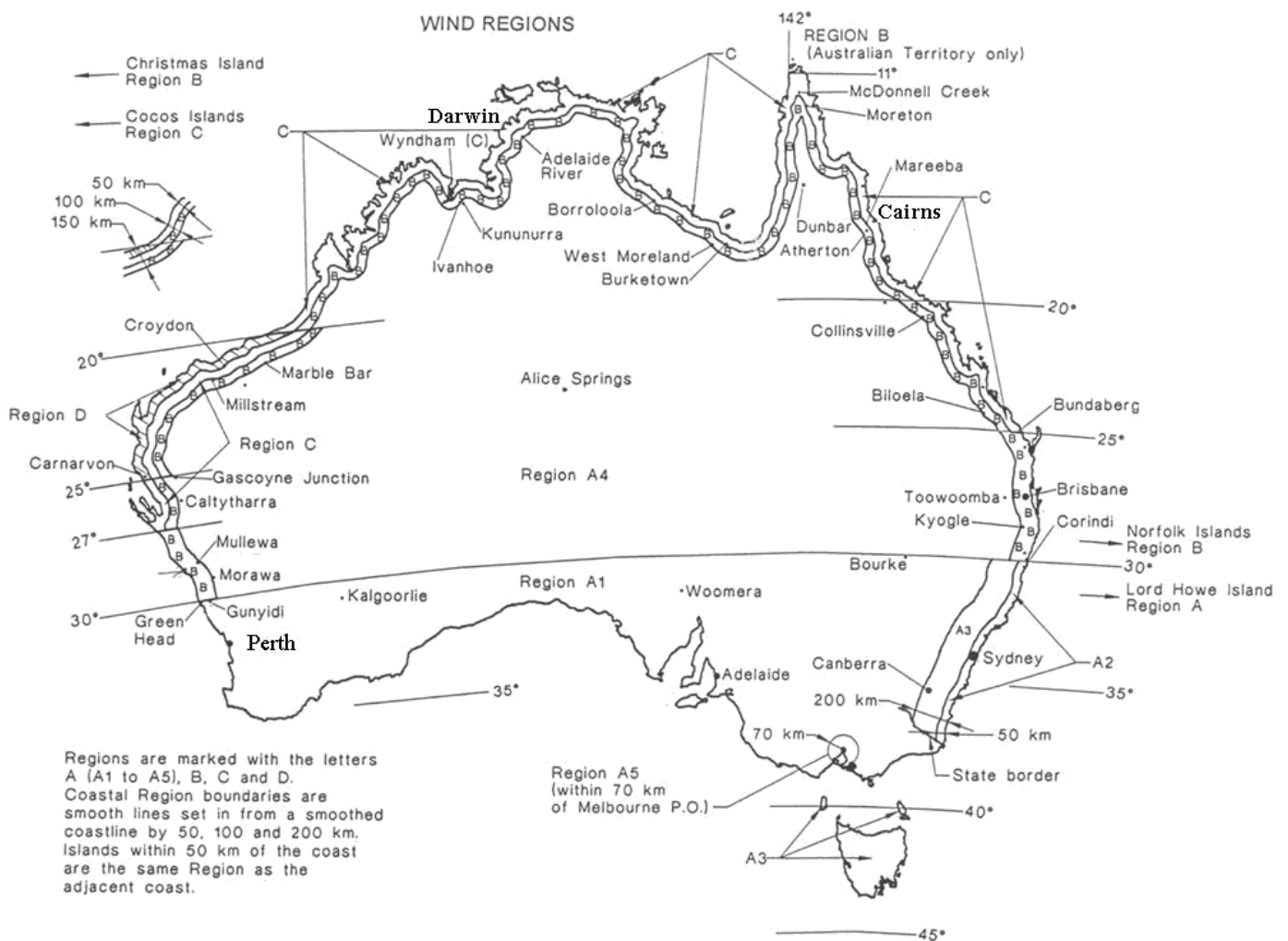

Figure 1 - Wind Regions - Australia AS 1170

4.2 Building / Installation Height

The Red-Dot-Rack Tripod system has been designed specifically for single storey and 2 storey buildings up to a maximum height of 10 m above ground. The system is applicable to flat concrete rooftops and metal sheet rooftops of up to 7 degrees pitch.

If you are intending to use the Red-Dot-Rack Tripod system for installations higher than 10 m above ground level you may need to purchase additional Red-Dot-Rack™ mounting components. Please contact a Red-DotRack™ technician directly for more information on these types of installations.

4.3 Solar Panel Layout

The Red-Dot-Rack Tripod kit is a modular system to which a range of solar panel modules can be mounted. Solar panels clamps to parallel rails that are aligned with and tied structurally to the Tripod kits. The Tripod Kits are then spaced at intervals determined by the spacing guidelines and fastened to the existing rooftop with a range of available rooftop mounting brackets.

Solar panels installed with the Red-Dot-Rack™ must follow the exclusion zone rules of:

- Front of tripod must have a clearance (X) of 300mm from the roof edge
- Clearance required for dimension (Z) of 300mm from the roof edge

The exclusion zone to the ridge and edges of the roof indicated below by distances A and B.

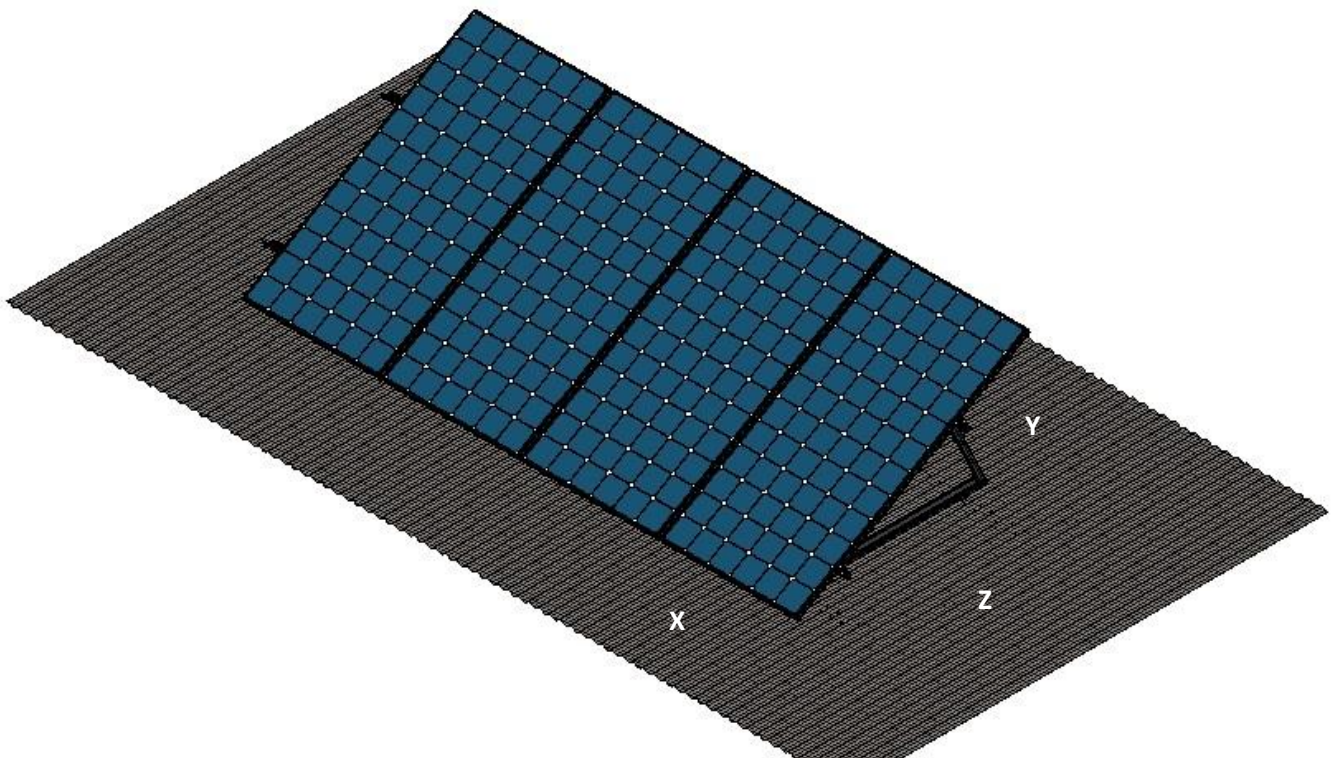
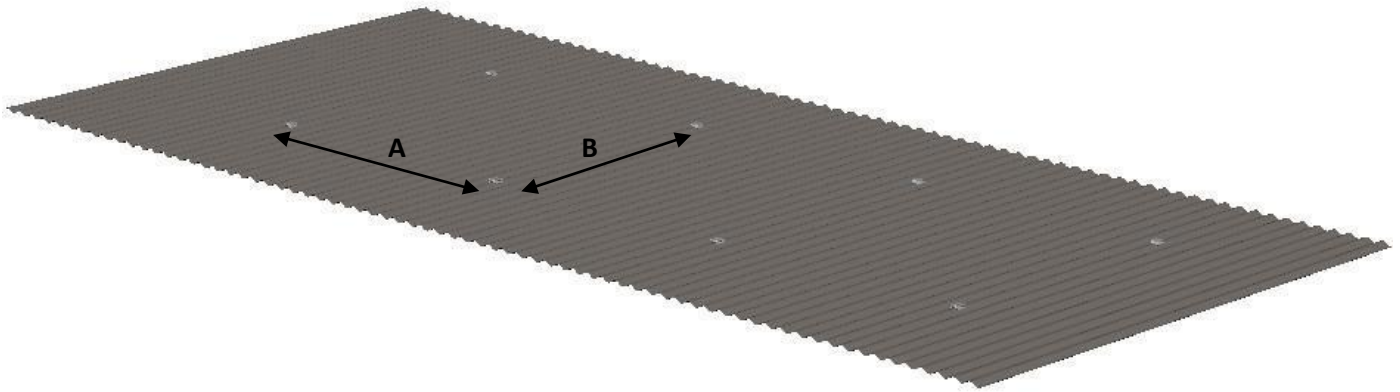

Figure 2 – Installation Exclusion Zones

4.4 General Installation Notes

1. The building to which the panels are installed shall be of approved construction and conform to BCA and the relevant Australian standards.
2. The spacings of the rail fixings (A) shall not exceed the recommended spacing as per **Bracket Spacing Guidelines Section 6.1**.
3. The spacings of the rail fixings (B) shall be reduced to match the location of the roof rafters.
4. All solar panels must be supported by a minimum of 2 rails.
5. The cantilever span of the solar panel shall not exceed 25% of its own length (i.e. 412mm for a 1650mm solar panel).
6. The cantilever span of the rail shall not exceed 50% of the applicable bracket spacing.
7. For concrete slabs use 2xM12 chemset anchors or similar. The waterproof membrane shall be reinstated after installation.



4.5 Fastening Torque of Bolts

All M8 sized diameter bolts in the RED-DOT-RACK product range are to be fastened to a torque of 8Nm. This is applicable to the bolts used in compression coupling brackets (e.g. KlipLok, VLock and Standing Seam variations) all module clamps (e.g. Mid-Clamps and End Clamps) and all accessories (e.g. Grounding Lug).

Over-tightening bolts in assembly may lead to damage to the mounting products and/or solar modules.

5.0 INSTALLATION OF MOUNTING BRACKETS

5.1 Installing Directly onto Corrugated Rooftops



Mount the Tripod Leg

1. Position and mark the installation points of the Folded Tripod Tilt Legs in accordance with the Bracket Spacing Guidelines Section 6.1 and ensure the fastening points are located over the center of the rafters.
2. Drill pilot holes in the metal roof sheet and steel rafter for the roofing screw.
3. Place an EPDM rubber pad supplied separately under each fastening point of the Folded Tripod Tilt Legs and over the pilot hole to ensure a watertight connection.
4. Secure the Folded Tripod Tilt Leg in place over the rubber pad with the roofing screw supplied.

Additional Assembly Information

- Do not over tighten screws or bolts during installation
- A minimum roof sheet thickness of 0.5 mm for Steel and 0.8 mm for Aluminum must be available.
- The roof structure must be able to provide adequate load bearing capabilities for the entire system. □
Once installed, roofing screws must not be removed and re-installed in the same position.

5.2 Installing onto Corrugated Rooftops with Corrugated Shoe (optional)

The Corrugated Shoe is used as an alternative to installing the Folded Tripod Tilt Legs directly onto the corrugated rooftop. The Corrugated Shoe provides additional support for accurately aligning the Folded Tripod Tilt Legs and prevents damage being caused to the roof sheet by providing additional support.

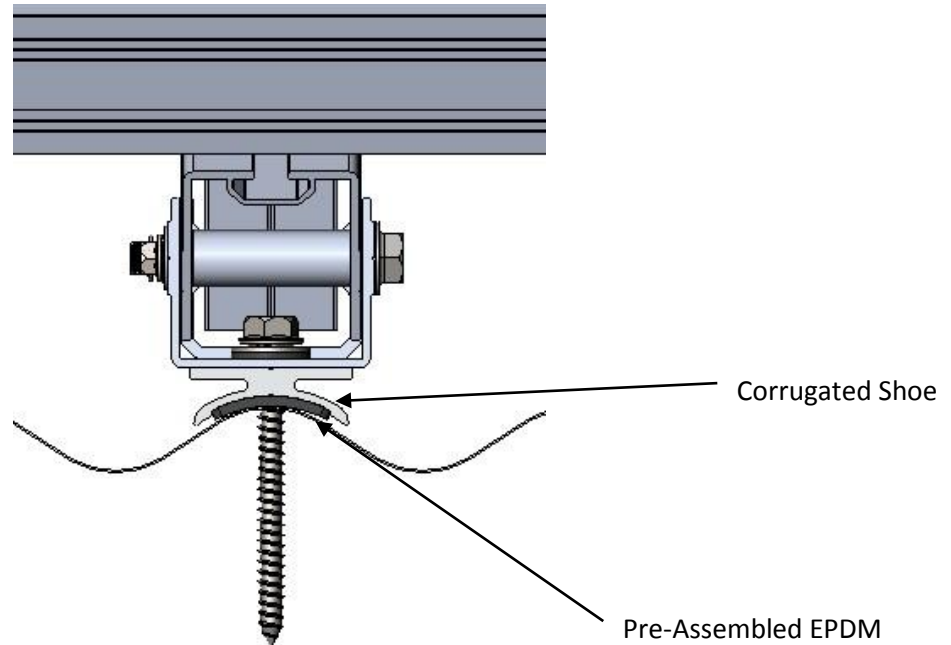

Mount the Tripod Leg

1. Position and mark the installation points of the Folded Tripod Tilt Legs in accordance with the Bracket Spacing Guidelines Section 6.1 and ensure the fastening points are located over the center of the rafters.
2. Drill pilot holes in the metal roof sheet and steel rafter for the roofing screw.
3. Place a Corrugated Shoe with assembled EPDM rubber pad under each fastening point of the Folded Tripod Tilt Legs and over the pilot hole to ensure a watertight connection.
4. Secure the Folded Tripod Tilt Leg in place over the Corrugated Shoe with the roofing screw supplied.

Additional Assembly Information

- Do not over tighten screws or bolts during installation
- A minimum roof sheet thickness of 0.5 mm for Steel and 0.8 mm for Aluminum must be available.
- The roof structure must be able to provide adequate load bearing capabilities for the entire system. □
Once installed, roofing screws must not be removed and re-installed in the same position.

5.3 Compression Coupling Bracket Mounting Instruction

Compression coupling brackets include; all KlipLok variations, Standing Seam and VLock brackets. All of these brackets secure the mounting system to the metal roof sheet via a compression force rather than anchoring with a penetrating roofing screw.

It is very important to select the correct bracket type for the rooftop being used. The wrong bracket may lead to system failure such as tear off from the building rooftop, causing damage to both the PV system and the existing building.

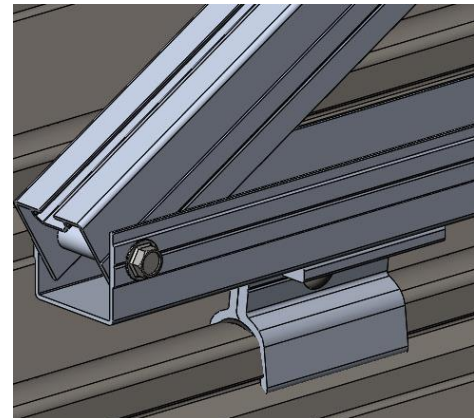
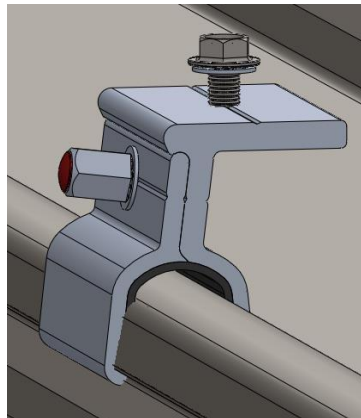
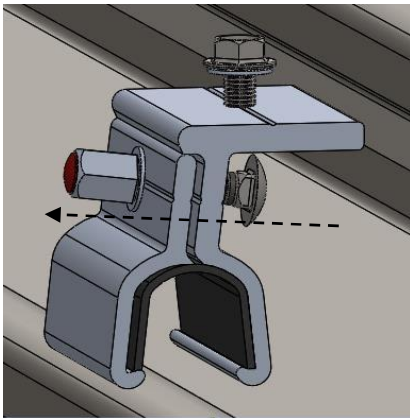

Mount the Tripod Leg

1. Insert the EPDM rubber piece (#102-0005) for galvanic separation of the bracket from the roof (optional if purchased).
2. Position and mark the installation points of the compression brackets over the center of the rafters. Ensure the distance from one rafter to the next does not exceed the distances stated in the Bracket Spacing Guidelines.
3. Fasten the compression bracket with the side screw to 8Nm torque so that both mating pieces come together around the metal sheet without leaving any visible gap.
4. Remove the screw from the top landing of the compression bracket.
5. Align the Folded Tripod Tilt Legs so that the mounting holes in the base rail meet with the threaded M8 holes in the compression coupling bracket.
6. Fasten the Folded Tripod Tilt Leg to the compression coupling bracket.

Additional Assembly Information

- Compression coupling brackets do not need to be installed directly over rafters, therefore provide a greater level of flexibility for installing the system.
- Avoid installing compression coupling brackets over rooftop joints.

5.4 Tripod Tilt Leg Setup

Once the Folded Tripod tilt Legs have been fastened to the rooftop mounting brackets, the right angle must be aligned.

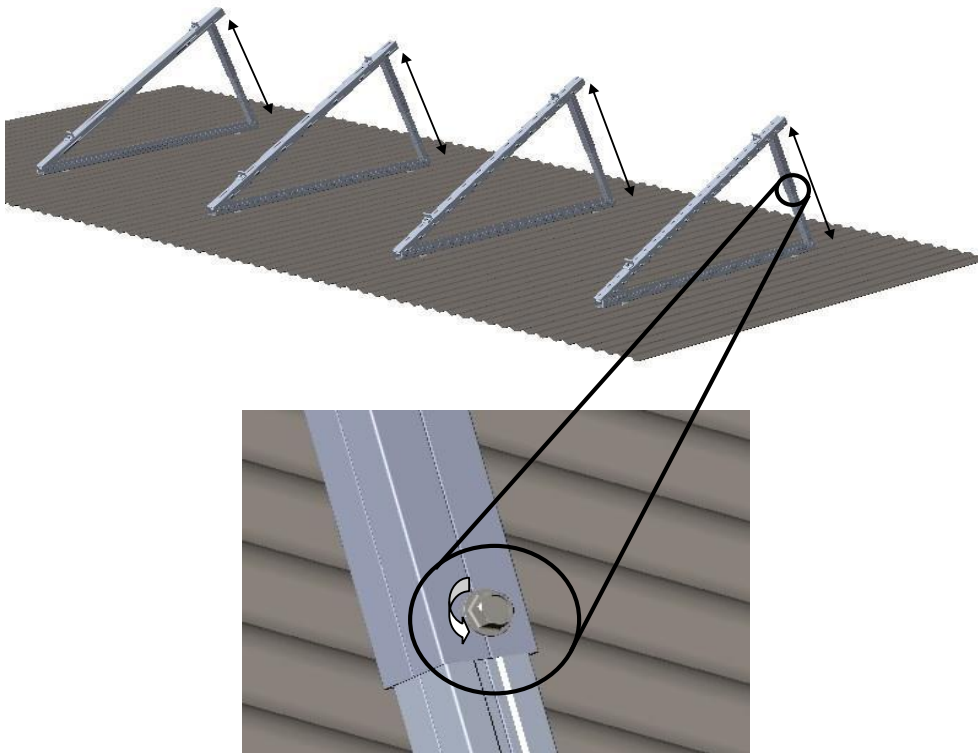

Adjust the Angle

1. Loosen the screw in the rear of the telescopic arm.
2. Adjust the length of the telescopic arm so that the desired pitch is achieved. Ensure that you are following the maximum allowable spacing for the pitch ranges of 0-15 degrees or 15-30 degrees.
3. Fasten the screw in the rear of the telescopic arm to lock in the required pitch.
4. Repeat for each of the Folded Tripod Tilt Leg in the row before proceeding to attach cross rails.
5. See below picture to setup location of telescopic arm

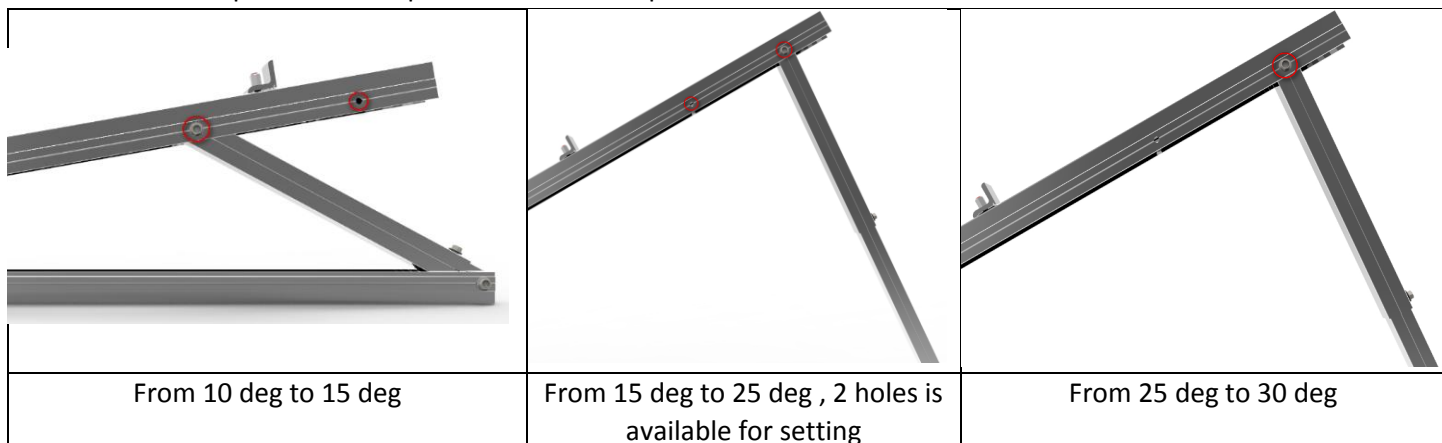

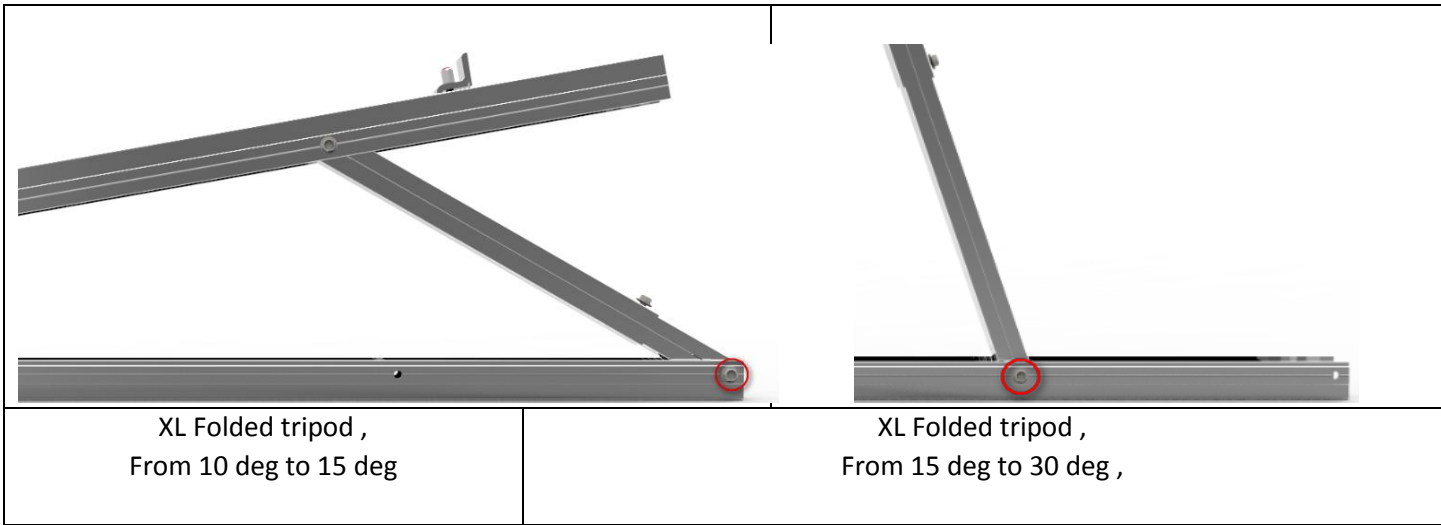

5.5 Rail Fastening Instruction

All Red-Dot-Rack rail lengths (2100mm, 3200mm, 4200mm and 5200mm) and custom lengths are compatible with the range of rooftop brackets available. The rails are fastened perpendicular to the Tripod Tilt Legs with the Cross Rail Bracket.

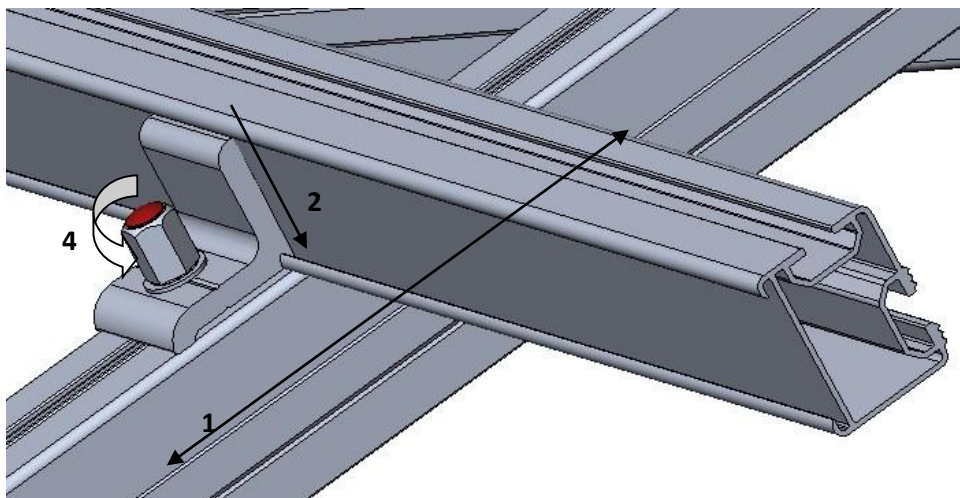

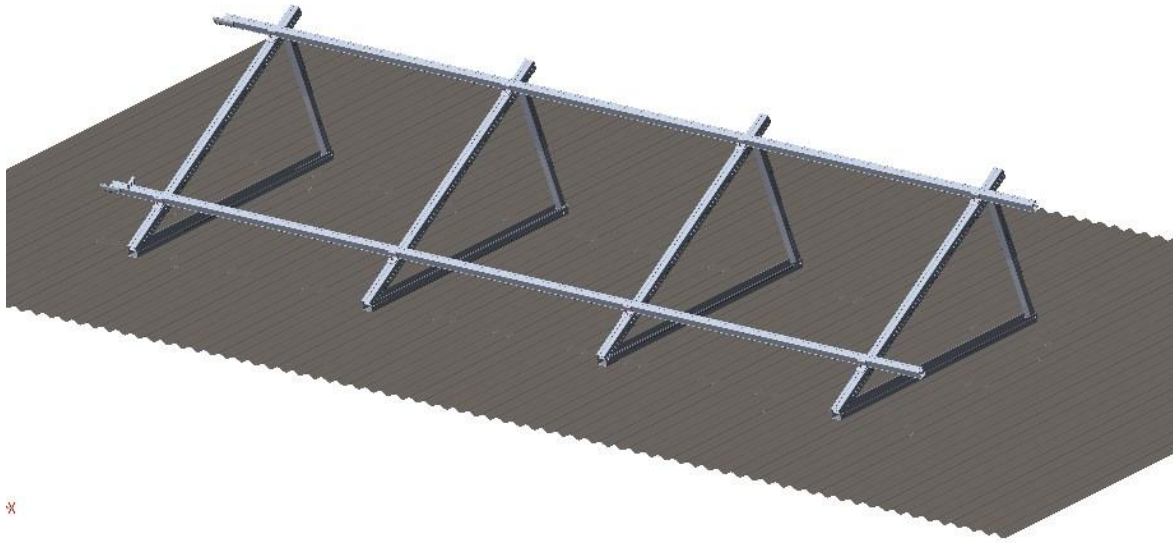

*

Rail Assembly Steps

1. Align the rail to be installed along the set of fastened Tripod Tilt Legs.
2. Hook a Cross Rail Bracket into the channel of the Cross Rail as shown.
3. Twist the T-Bolt into place in the channel of the top Tripod Tilt Leg.
4. Fasten the connector nuts with a torque of 8Nm to ensure a tight connection.

5.6 Rail Splice Instruction

Where long arrays (over 5 solar panels) are installed the rails can be joined together by applying a rail joiner to each break. The rail joiner consists of one aluminium splice and 2 screws as a set.

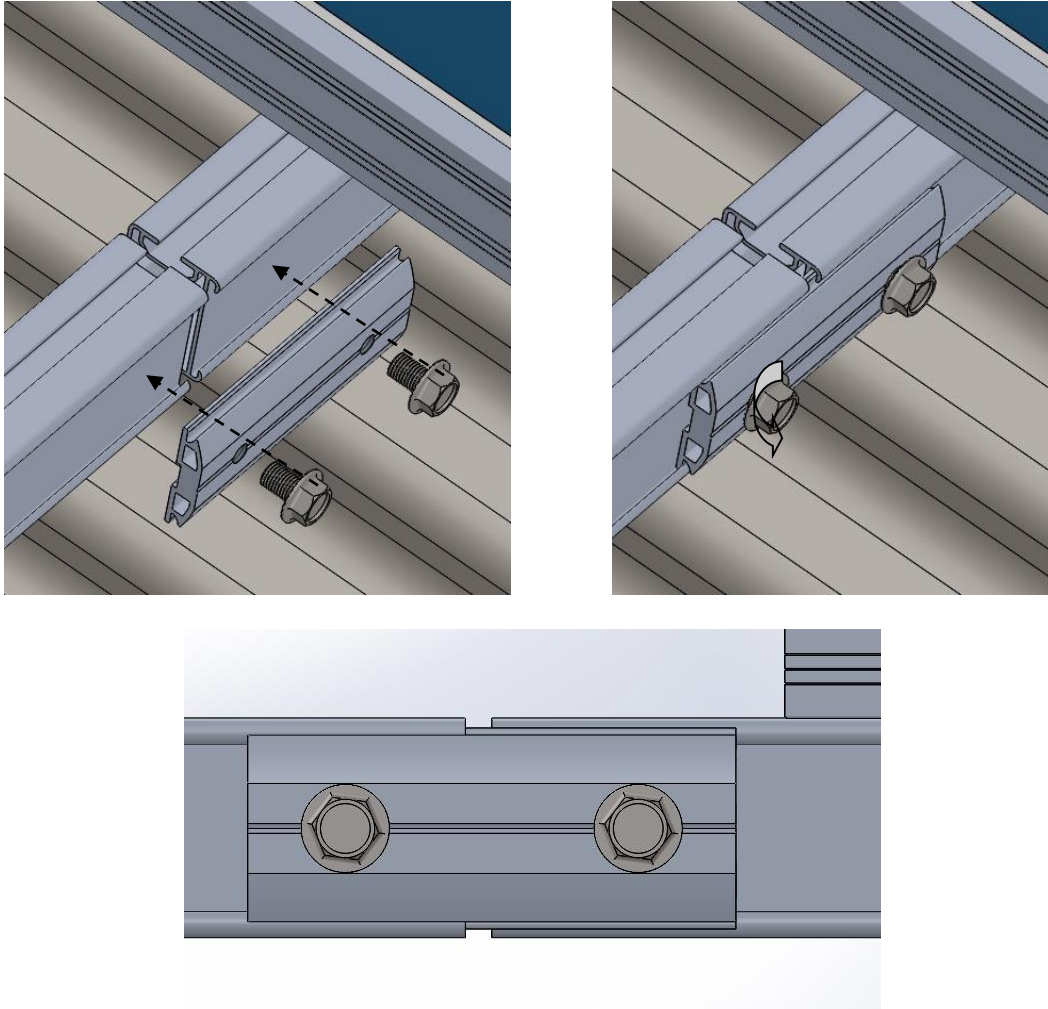

Assembly steps

1. Once the rooftop brackets have been installed, align the two rails end to end allowing the break to meet flush. The rail connectors should not yet be fully fastened.
2. Insert the aluminium rail joiner splice piece so that it sits evenly across the two pieces of rail, with approximately 50mm length installed into each rail.
3. Insert and fasten the two screws supplied to a torque of 8Nm
4. Once the rail joiner has been installed the rail nut connectors can be fully fastened to 8Nm each to ensure a tight connection over the entire length of extended rail.

5.7 Solar Panel Module Installation

WARNING

ENSURE YOU FOLLOW ALL RECOMMENDATIONS AND INSTRUCTIONS OF THE SOLAR PANEL MANUFACTURER IN HANDLING AND INSTALLING THE SOLAR PANELS.

Solar panels are fastened to the Red-Dot-Rack rooftop system one panel at a time. Ensure to use a suitable means to prevent the panels slipping from the frame during installation. Falling panels may cause damage to equipment and harm to others in the construction area.

Once installed, the Mid-Clamps and End clamps will hold the solar panel panels in place even in extreme weather conditions. Until the clamps are securely installed, the solar panel module needs to be appropriately secured.

5.8 End Clamps

Adjustable solar panel end clamps are designed to suit solar panels with thickness ranging between 31mm and 50mm. Do not attempt to install solar panels with a thickness outside of this range. If you should have any solar panels outside of the 31-50mm range please contact Red-Dot-Rack for the custom range of products.

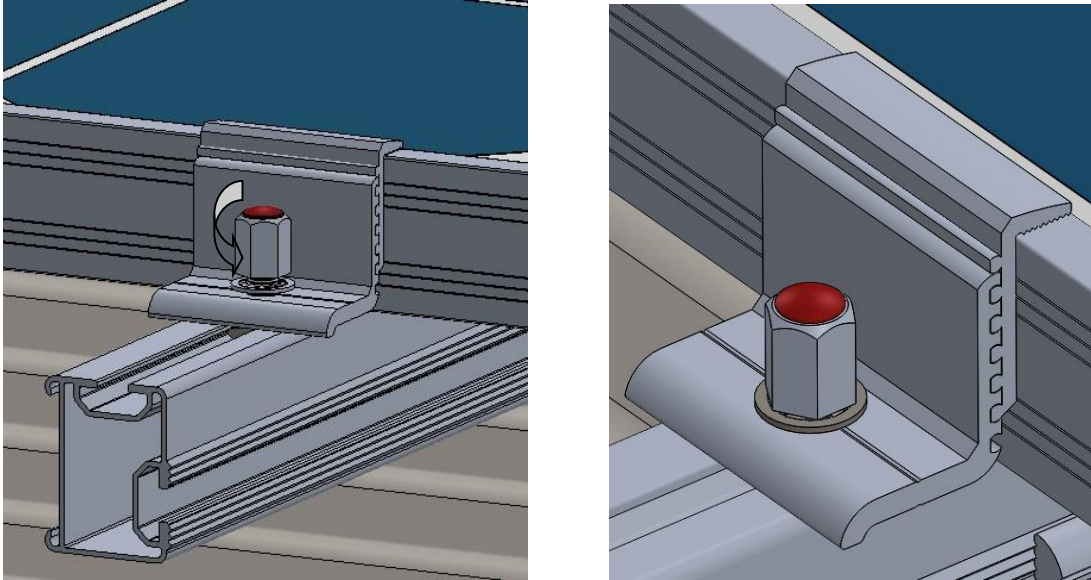

Assembly steps

1. Determine the thickness of your solar panel by checking the manufacturer specification sheets.
2. Set the end clamp height to the solar panel thickness by removing the top piece and inserting at the correct location.
3. Insert the T-Bolt head into the channel on the top of the rail and twist to lock in place.
4. Fasten the end clamp firmly against the solar panel with a torque of 8Nm. Do not over fasten the end clamp or else damage to the solar panel frame may occur.

5.9 Mid Clamps

Adjustable solar panel mid-clamps are designed to suit solar panels with thickness ranging between 31mm and 50mm with the use of a custom design spring.

Do not attempt to install solar panels with a thickness outside of this range. If you should have any solar panels outside of the 31-50mm range please contact Red-Dot-Rack for the custom range of products.

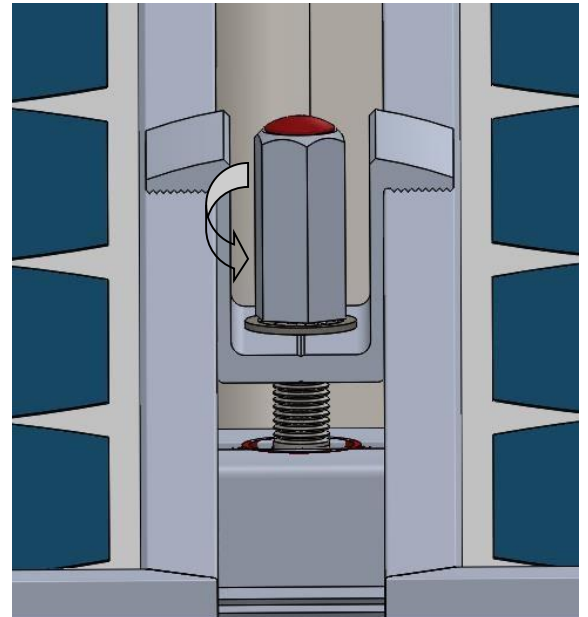
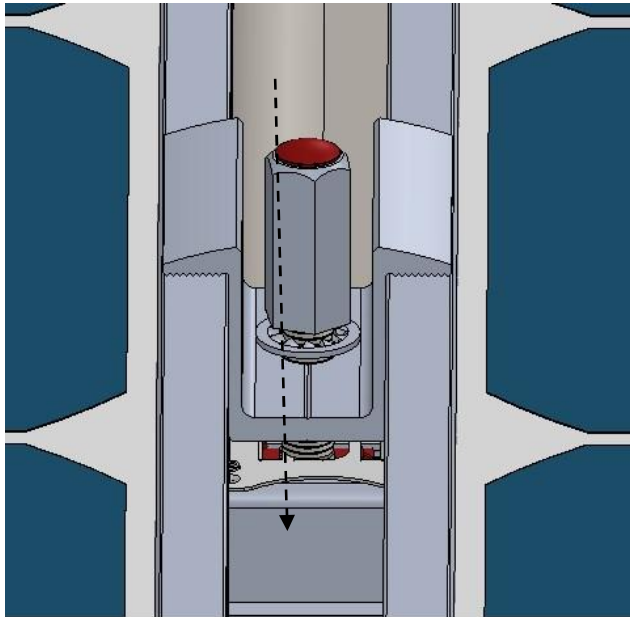

Assembly steps

1. Insert the T-Bolt head into the channel on the top of the rail and twist to lock in place.
2. By pressing the top of the mid-clamp down by hand, position the mid clamp firmly against the top edge of the solar panel frame.
3. Turn the nut to achieve a loose fit.
4. Slide the adjoining solar panel along the rail and under the mid clamp.
5. Ensure that the mid clamp is tight against the solar panel modules.
6. Fasten the mid-clamp firmly against the solar panel with a torque of 8Nm. Do not over fasten the end clamp or else damage to the solar panel frame may occur.

5.0 GROUNDING COMPONENTS

5.1. Mid Clamp Earthing Washer

The mid-clamp earthing washer is a stainless steel plate which provides a grounding bond between the solar panel frame and the mounting structure rails by making a small engraving through the anodized coating on the aluminium during installation.

The mid-clamp earthing washer is installed as an alternate pre-assembled product of the standard mid-clamp. Simply insert the rail connector into the top channel of the rail as per the standard mid clamp and position the stainless steel plate evenly under the solar panel frame on each side.

While fastening the solar panel ensure that the mid-clamp earthing washer does not rotate out from under the solar panel frames.

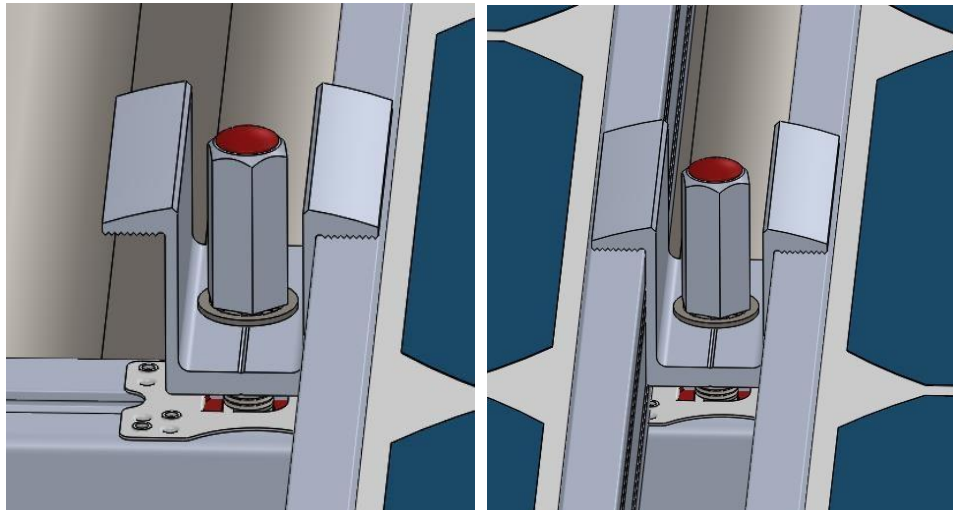

5.2. Earthing Lug

The earthing lug provides a grounding bond between the mounting structure rails and the common electrical ground via a grounding wire. In a system where the mid-clamp with earthing washer has been installed, the earthing lug will complete the grounding circuit.

Assembly Steps

1. Insert the T-Bolt head into the channel on the top of the rail and twist to lock in place.
2. Align the steel washer and aluminium pieces so that it sits across the channel
3. Insert the stripped end of the system grounding wire into the Earthing Lug port holes and fasten the assembly with a 8Nm torque.

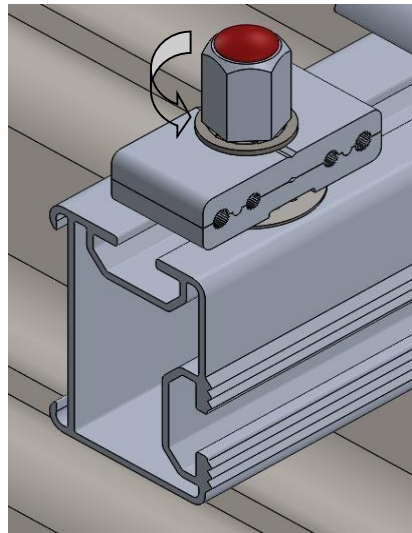
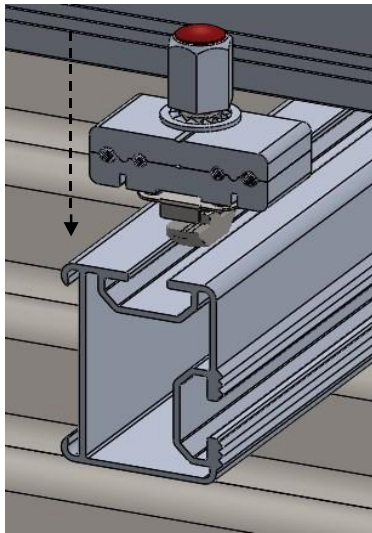

Note: Red-Dot-Rack does not enforce the application of earthing components with the mounting structure. Grounding laws vary in different countries and with different installation types, and therefore may not be necessary to every installation. Please check with your local laws to ensure your installation complies to the required standards.

6.0 Bracket Spacing Guidelines

The following determines the maximum bracket spacing applicable for your installation. Ensure you refer to the correct roof type, roof pitch angle, wind region and roof zone while planning your installation.

Red-Dot-Rack kits include sufficient materials for all wind Region A and Region B installations. Use the bracket spacing guidelines to determine the quantity of additional brackets required for any wind Region C and Region D installations.

6.1. Bracket Spacing for Tripod (Solar panel 60cell)

Table 1.1		1650 Long.		Inclination 0 - 15 degrees	
Maximum spacing of the fixing of the Back Legs (mm) Railing: Pro Standard Rail t1.2.					
Roof Height	Region A	Region B	Region C	Region D	
5m	1980	1450	860	540	
10m	1780	1190	770	490	
15m	1600	1070	670	420	
20m	1510	1010	600	380	

Table 1.2.		1650 Long.		Inclination 15 - 30 degrees	
Maximum spacing of the fixing of the Back Legs (mm) Railing: Pro Standard Rail t1.2.					
Roof Height	Region A	Region B	Region C	Region D	
5m	1210	820	490	310	
10m	1000	670	440	280	
15m	900	610	380	240	
20m	850	570	340	220	

Table 2.1.		1970 Long.		Inclination 0 - 15 degrees	
Maximum spacing of the fixing of the Back Legs (mm) Railing: Pro Standard Rail t1.2.					
Roof Height	Region A	Region B	Region C	Region D	
5m	1810	1210	720	450	
10m	1490	990	650	410	
15m	1340	900	560	360	
20m	1260	850	500	320	

Table 2.2.		1970 Long.		Inclination 15 - 30 degrees	
Maximum spacing of the fixing of the Back Legs (mm) Railing: Pro Standard Rail t1.2.					
Roof Height	Region A	Region B	Region C	Region D	
5m	1020	680	410	260	
10m	840	560	370	230	
15m	750	510	320	200	
20m	710	480	290	180	

6.2. Bracket Spacing for Tripod (Solar panel 72cell)

Table 1.1		1650 Long.		Inclination 10 - 15 degrees	
Maximum spacing of the fixing of the Back Legs (mm) Railing: Pro Standard Rail t1.2.					
Roof Height	Region A	Region B	Region C	Region D	
5m	1770	1180	700	440	
10m	1450	970	630	400	
15m	1300	880	550	350	
20m	1230	830	490	310	

Table 1.2.		1650 Long.		Inclination 20 - 30 degrees	
Maximum spacing of the fixing of the Back Legs (mm) Railing:: Pro Standard Rail t1.2.					
Roof Height	Region A	Region B	Region C	Region D	
5m	1210	820	490	310	
10m	1000	670	440	280	
15m	900	610	380	240	
20m	850	570	340	220	

Table 2.1. 1970 Long. Inclination 10 - 15 degrees				
Maximum spacing of the fixing of the Back Legs (mm) Railing: Pro Standard Rail t1.2.				
Roof Height	Region A	Region B	Region C	Region D
5m	1480	980	580	370
10m	1210	810	520	330
15m	1090	730	460	290
20m	1020	690	410	260

Table 2.2. 1970 Long. Inclination 20 - 30 degrees				
Maximum spacing of the fixing of the Back Legs (mm) Railing: Pro Standard Rail t1.2.				
Roof Height	Region A	Region B	Region C	Region D
5m	1020	680	410	260
10m	840	560	370	230
15m	750	510	320	200
20m	710	480	290	180

7.0 CONTACT DETAILS

For technical questions, please contact us via the following details:

Email: info@Red-Dot-Rack.com

Phone:

Website: www.reddotrack.com